

User manual
NIBE™ ERS 10-50
Ventilation heat exchanger

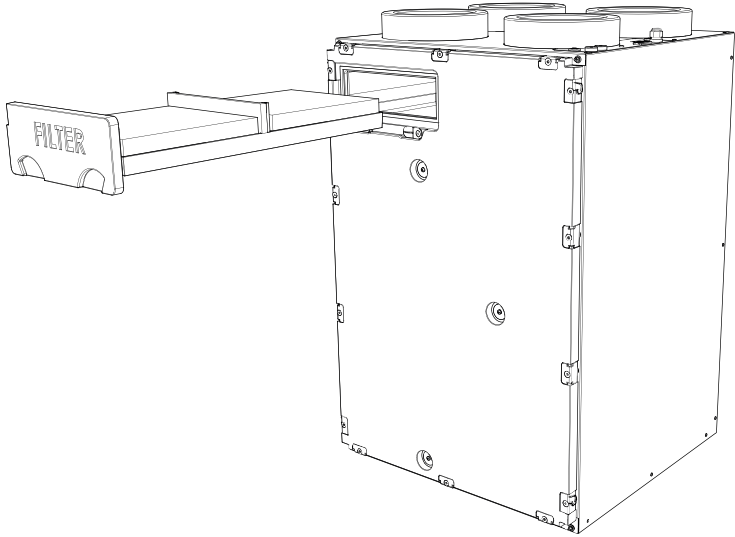
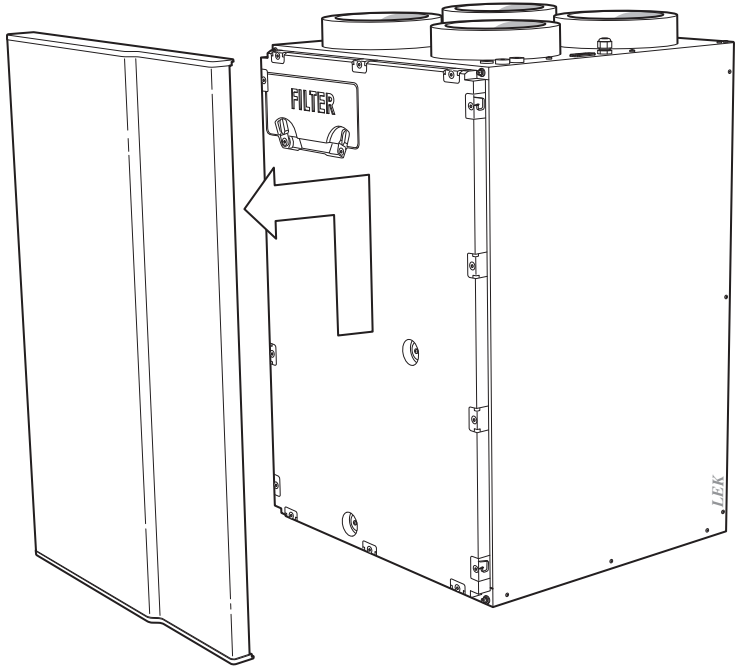

Table of Contents

1	<i>Important information</i> _____	4
	Installation data _____	4
	Safety information _____	5
	Serial number _____	6
	ERS 10 - An excellent choice _____	7
2	<i>The heating installation – the heart of the house</i> _____	8
	Ventilation heat exchange function _____	9
	Maintenance of ERS 10 _____	10
3	<i>Disturbances in comfort</i> _____	13
	Info-menu _____	13
	Manage alarm _____	13
	Troubleshooting _____	15
4	<i>Technical data</i> _____	17
5	<i>Glossary</i> _____	18
	<i>Contact information</i> _____	19

1 Important information

Installation data

Product	ERS 10
Serial number	
Installation date	
Installer	

No.	Name	Factory settings	Set
5.1.5	fan sp. exhaust air normal	75%	
5.1.6	fan sp. supply air normal	60%	
5.3.12	exhaust/supply air module lowest extract air temp. bypass at temperature	5 °C 4 °C	

Serial number must always be given

It is hereby certified that the installation has been carried out in accordance with the instructions in the Installer manual and applicable regulations.

Date _____ Signed _____

Safety information

This appliance can be used by children aged from 8 years and above and persons with reduced physical, sensory or mental capabilities or lack of experience and knowledge if they have been given supervision or instruction concerning use of the appliance in a safe way and understand the hazards involved. Children shall not play with the appliance. Cleaning and user maintenance shall not be made by children without supervision.

Rights to make any design or technical modifications are reserved.

©NIBE 2016.

Symbols



NOTE

This symbol indicates danger to machine or person.



Caution

This symbol indicates important information about what you should observe when maintaining your installation.



TIP

This symbol indicates tips on how to facilitate using the product.

Marking

The CE marking means that NIBE ensures that the product meets all regulations that are placed on it based on relevant EU directives. The CE mark is obligatory for most products sold in the EU, regardless where they are made.

Serial number

The serial number can be found at the top right inside the front hatch.

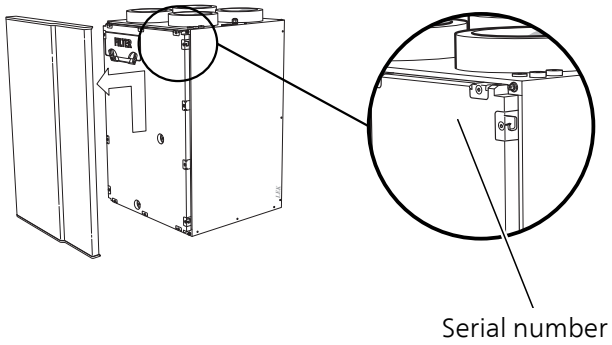

Caution

Always give the product's serial number when reporting a fault.

ERS 10 - An excellent choice

ERS 10 is a ventilation heat exchanger with high temperature efficiency and low energy consumption.

Excellent properties for ERS 10:

- ***DC fans***

Two energy efficient DC fan (Class A) are integrated in the ventilation heat exchanger.

- ***Low noise level***

The ventilation heat exchanger has a very low noise level.

- ***Easy to install***

The ventilation heat exchanger is easy to install together with a NIBE heat pump or indoor module. During installation, the ventilation heat exchanger is connected to the main product, which enables you to read off the exhaust air module's values from the main product's display.

2 The heating installation – the heart of the house

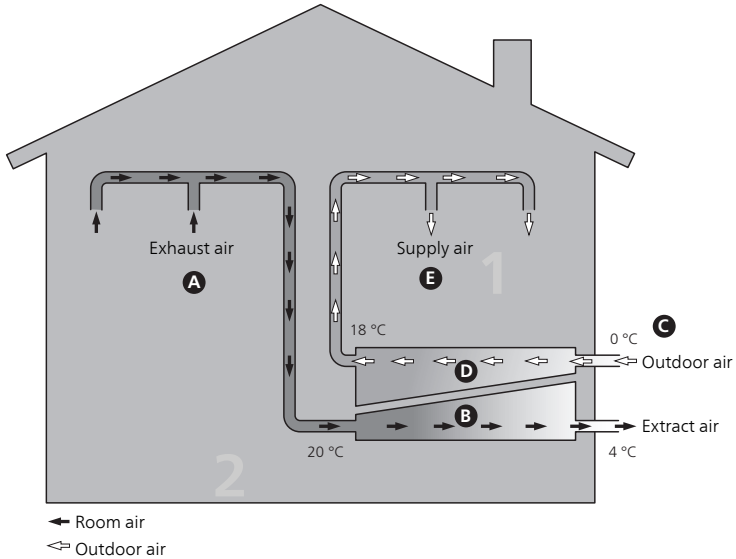

The temperatures are only examples and may vary between different installations and time of year.

Ventilation heat exchange function

An ventilation heat exchanger makes use of the heat in the building's ventilation air to heat up the incoming outdoor air. From the outgoing ventilation air (1), free heating energy is retrieved from the accommodation and transported to the heat exchanger. The exchanger (2) transfers the heat from the indoor air to the incoming outdoor air.

Ventilation air

- A** The hot air is transferred from the rooms to the heat exchanger via the building's ventilation system using a fan.
- B** In the ventilation heat exchanger the air releases heat energy and the air's temperature drops significantly. The cold air is then blown out of the house.

Outdoor air

- C** The outdoor air is transferred to the ventilation heat exchanger via the house's ventilation system.
- D** In the ventilation heat exchanger the air releases the heating energy and the temperature is raised.
- E** A fan blows the heated air into those rooms that have supply air inlets.

Maintenance of ERS 10

Regular checks

Your ventilation heat exchanger requires minimal maintenance after commissioning. On the other hand, it is recommended that you check your installation regularly.

If something unusual occurs, messages about the malfunction, in the form of different alarm texts, appear in the main product display.

NOTE

Always cut the power before opening ERS 10.

Cleaning the ventilation devices

The building's ventilation devices should be cleaned regularly with, for example, a small brush to maintain the correct ventilation.

The device settings must not be changed.

NOTE

If you take down more than one ventilation device for cleaning, do not mix them up.

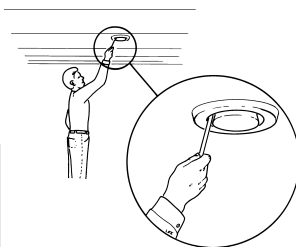

Cleaning the air filter

Clean the filters in ERS 10 regularly, how often depends on the amount of dust in the ventilation air. Test until you find what is most suitable for your installation. Remember that the efficiency of the installation can be reduced by a dirty air filter.

You will receive a reminder to clean the filters in the main product's display. The default setting for the reminder is every three months, however, if the power to the main product is interrupted the countdown begins again.

1. Switch off the installation using the MCB in the fuse box or the main switch for the installation.
2. Remove the front hatch by lifting it slightly and then pulling it towards you.

3. Pull out the filter cassette.

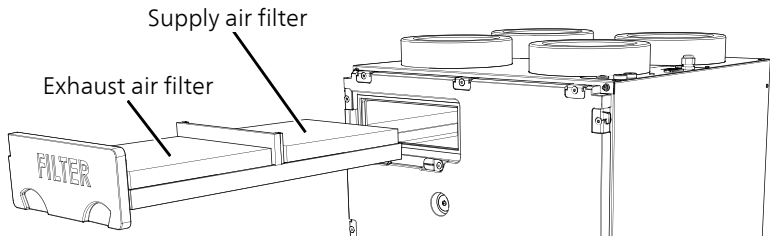

4. Remove the filters and shake/vacuum them clean or replace both filters. Water or other liquids must not be used for cleaning.
5. Check that the filters are not damaged.
6. Carry out assembly in reverse order.

Even if the filters appear clean, dirt collects in them and this affects the efficiency of the filters. Therefore, both the exhaust air and supply air filters must be replaced annually. New filters can be ordered via the installer.

Supply air filter: F7 = Pollen filter (Fine filter class F7)

Exhaust air filter: G4 = Standard filter (Coarse filter class G4)

NOTE

Use of a vacuum cleaner or compressed air on the filter is not recommended, as this diminishes the degree of filtration.

Check the water lock for condensation water

The water seal is located outside ERS 10. Contact your installer if you are unsure of where to find it.

The water seal may dry out during the hotter periods of the year when no condensation is generated. Therefore, before the cold periods of the year, the condensation water drain must be checked for blockage due to dirt and filled with water.

Pour approx. one litre of water into the water seal and check that it runs through unobstructed.

The water seal must not dry out during those months of the year that condensation is created because, due to the negative pressure in the unit, air will be sucked into the unit which will then prevent the condensation water from running off. ERS 10 can produce several litres of condensation water each day. If the condensation water drain does not function, water may cause damage inside the house.

Cleaning the heat exchanger

The heat exchanger in ERS 10 must be inspected at regular intervals. Every other year is recommended. Contact your installer for assistance with cleaning.

3 Disturbances in comfort

In most cases, the main product notes a malfunction (a malfunction can lead to disturbance in comfort) and indicates this with alarms and shows action instructions in the display.

Info-menu

All these measurement values are gathered under menu 3.1 in the main product's menu system. Looking through the values in this menu can often simplify finding the source of the fault. See the main product's user manual for more information about menus 3.1.

Manage alarm

In the event of an alarm, some kind of malfunction has occurred, which is indicated by the status lamp changing from green continuously to red continuously. In addition, an alarm bell appears in the information window.

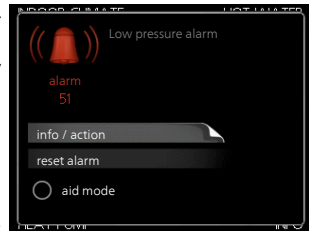

Alarm

In the event of an alarm with a red status lamp, a malfunction has occurred that the main product cannot remedy itself. By turning the control knob and pressing the OK button, you can see in the display what type of alarm it is and reset it. You can also choose to set the main product in aid mode.

info / action Here you can read what the alarm means and receive tips on what you can do to correct the problem that caused the alarm.

reset alarm In most cases it is enough to select "reset alarm" to correct the problem that caused the alarm. If a green light illuminates after selecting "reset alarm" the alarm has been remedied. If a red light is still visible and a menu called "alarm" is visible in the display, the problem that caused the alarm remains. If the alarm disappears and then returns, contact your installer.

aid mode "aid mode" is a type of emergency mode. This means that the heat pump produces heat and/or hot water despite there being some kind of problem with the heat pump. This can mean that the heat pump's compressor is not running. In this case the immersion heater produces heat and/or hot water.

Problems with ERS 10 do not affect the main product's operation. You therefore do not need to select "aid mode" in event of problems with ERS 10.

**Caution**

Selecting "aid mode" is not the same as correcting the problem that caused the alarm. The status lamp will therefore continue to be red.

If the alarm does not reset, contact your installer for suitable remedial action.

**NOTE**

Always state the heat pump's and ventilation heat exchanger's serial numbers when contacting your installer.

Troubleshooting

If the operational interference is not shown in the display the following tips can be used:

Basic actions

Start by checking the following possible fault sources:

- That the main product is running and that the supply cable to ERS 10 is connected.
- Group and main fuses of the accommodation.
- The property's earth circuit breaker.

High or low room temperature

- See user manual for the main product.

Low or a lack of ventilation

- Level monitor tripped.
 - Checking the condensation water drain and water seal.
- Filter blocked.
 - Clean or replace filter (see page 10).
- The ventilation is not adjusted.
 - Order ventilation adjustment.
- Closed, too much choke or blocked ventilation device.
 - Check and clean ventilation valves (see page 10).
- Fan speed in reduced mode.
 - Enter the main product's menu 1.2 and select "normal".
- External switch for changing the fan speed activated.
 - Check any external switches.
- Fan running slow because of low incoming outdoor air temperature.
 - Contact the installer in the event of recurring problems.

High or distracting ventilation

- Filter blocked.
 - Clean or replace filter (see page 10).
- The ventilation is not adjusted.
 - Order ventilation adjustment.
- Closed, too much choke or blocked ventilation device.

- Check and clean ventilation valves (see page 10).
- Fan speed in forced mode.
 - Enter the main product's menu 1.2 and select "normal".
- External switch for changing the fan speed activated.
 - Check any external switches.
- Silencers not correctly installed.
 - Contact your installer!

4 Technical data

Detailed technical specifications for this product can be found in the installation manual (www.nibe.eu).

5 Glossary

Climate system

The climate system can also be called the heating and/or cooling system. The building is cooled or heated using radiators, under floor coils or convector fans.

Disturbances in comfort

Disturbances in comfort means unwanted changes in the indoor comfort, e.g. that the indoor temperature is not at the desired level.

Exhaust air

The air that comes from the exhaust air device in the various rooms of the accommodation, to ERS 10.

Exhaust air devices

Vents, usually in the ceiling, in the kitchen/bathroom/clothes closet where the air is drawn in to be forwarded to ERS 10.

Extract air

The air from which the ERS 10 has retrieved heat, and thereby cooled. This air is blown out of the house.

Heat exchanger

Device that transfers heat energy from one medium to another without mixing mediums. Examples of different heat exchangers are evaporators and condensers.

Outdoor air

Air that is drawn into the ERS 10 and heated.

Supply air

The heated air that is blown from ERS 10 and out into the room.

Supply air device

Valves, usually in the ceiling, where the heated supply air is blown out and aids in heating up the accommodation.

Contact information

- AT KNV Energietechnik GmbH**, Gahberggasse 11, AT-4861 Schörföling
Tel: +43 (0)7662 8963 E-mail: mail@knv.at www.knv.at
- CH NIBE Wärmetechnik c/o ait Schweiz AG**,
Industriepark, CH-6246 Altishofen Tel: +41 58 252 21 00
E-mail: info@nibe.ch www.nibe.ch
- CZ Druzstevni zavody Drazice s.r.o.**,
Drazice 69, CZ - 294 71 Benatky nad Jizerou
Tel: +420 326 373 801 E-mail: nibe@nibe.cz www.nibe.cz
- DE NIBE Systemtechnik GmbH**, Am Reiherpfahl 3, 29223 Celle
Tel: +49 (0)5141 7546-0 E-mail: info@nibe.de www.nibe.de
- DK Vølund Varmeteknik A/S**, Member of the Nibe Group,
Brogårdsvej 7, 6920 Videbæk Tel: +45 97 17 20 33
E-mail: info@volundvt.dk www.volundvt.dk
- FI NIBE Energy Systems OY**, Juurakkotie 3, 01510 Vantaa
Tel: +358 (0)9-274 6970 E-mail: info@nibe.fi www.nibe.fi
- FR NIBE Energy Systems France Sarl**,
Zone industrielle RD 28, Rue du Pou du Ciel, 01600 Reyrieux
Tel : 04 74 00 92 92 E-mail: info@nibe.fr www.nibe.fr
- GB NIBE Energy Systems Ltd**,
3C Broom Business Park, Bridge Way, S419QG Chesterfield
Tel: +44 (0)845 095 1200 E-mail: info@nibe.co.uk www.nibe.co.uk
- NL NIBE Energietechniek B.V.**, Postbus 634, NL 4900 AP Oosterhout
Tel: 0168 477722 E-mail: info@nibenl.nl www.nibenl.nl
- NO ABK AS**, Brobekkveien 80, 0582 Oslo, Postboks 64 Vollebakk, 0516 Oslo
Tel: +47 23 17 05 20 E-mail: post@abkklima.no
www.nibeenergysystems.no
- PL NIBE-BIAWAR Sp. z o. o.** Aleja Jana Pawła II 57, 15-703 BIALYSTOK
Tel: +48 (0)85 662 84 90 E-mail: sekretariat@biawar.com.pl
www.biawar.com.pl
- RU © "EVAN"** 17, per. Boynovskiy, RU-603024 Nizhny Novgorod
Tel: +7 831 419 57 06 E-mail: kuzmin@evan.ru www.nibe-egan.ru
- SE NIBE AB Sweden**, Box 14, Hannabadsvägen 5, SE-285 21 Markaryd
Tel: +46 (0)433 73 000 E-mail: info@nibe.se www.nibe.se

For countries not mention in this list, please contact Nibe Sweden or check www.nibe.eu for more information.

NIBE AB Sweden
Hannabadsvägen 5
Box 14
SE-285 21 Markaryd
info@nibe.se
www.nibe.eu

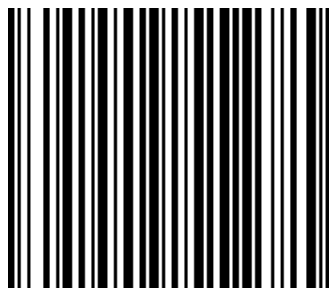

331807